



**CE Ex Group II Category 3G c T3 / 3D c T125°C**

**TECHNICAL CHARACTERISTICS**

- Unit in conformity to :  
ATEX 94/9/CE DIRECTIVE  
MACHINERY DIRECTIVE 98/37/CE
- Mountable in any plane
- E-motors thermally protected with Klixon
- Complete with metallic screen IP20, both in in/outlets ports
- G1/8" female thread on both suction and discharge silencer port flanges.

**OPTIONS**

- Special voltages (IEC 38)
- Surface treatments

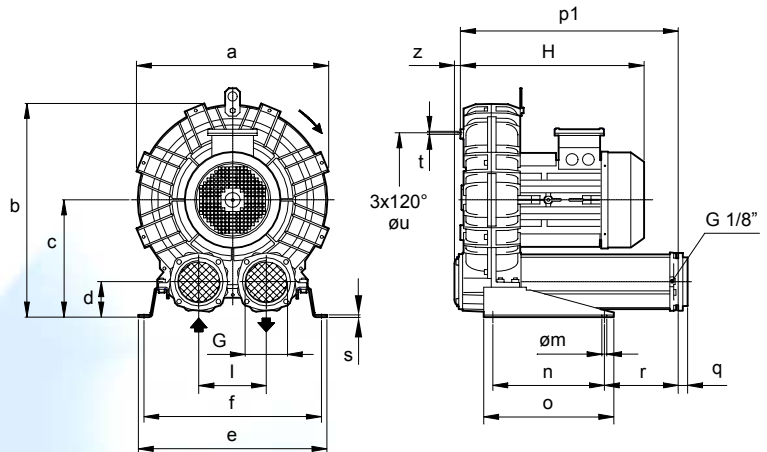

Dimensions in mm.  
 Dimensions for reference only.

Model	a	b	c	d	e	f	G	l	m	n	o	p1	q	r	s	t	u	z
K07-MS	424	481	269	82	468	438	G 3"	155	13	300	350	512	25	137	5	M8	295	16
K75-MS	424	481	269	82	468	438	G 3"	155	13	300	350	512	25	137	5	M8	295	16
K08-MS	457	498	269	82	478	448	G 3"	155	13	300	350	512	25	137	5	M8	310	16
K09-MS	492	561	315	96	508	478	G 4"	182	13	300	350	586	25	199	5	M8	360	16
K10-MS	516	573	315	96	508	478	G 4"	182	13	300	350	586	25	199	5	M8	360	16
K11-MS	542	603	332	91	538	508	G 4"	200	13	300	350	596	25	204	5	M8	390	16

Model	Maximum flow m³/h		Installed power kW		Maximum differential pressure Δp hPa ( mbar )		Noise level Lp dB (A) <sup>(1)</sup>		Overall dimensions H mm	Weight Kg
	50 Hz 2900 rpm	60 Hz 3500 rpm	50 Hz 2900 rpm	60 Hz 3500 rpm	50 Hz 2900 rpm	60 Hz 3500 rpm	50 Hz 2900 rpm	60 Hz 3500 rpm		
K07-MS	414	500	3.0	3.5	175	140	76.7	78.7	455	51.0
			4.0	4.6	225	185	77.0	79.0	477	59.5
			5.5	6.3	300	275	77.3	79.3	535	70.5
K75-MS	477	576	4.0	4.6	150	100	77.4	79.4	477	60.0
			5.5	6.3	215	165	77.7	79.7	535	71.0
			7.5	8.6	285	265	78.0	80.0	535	76.5
K08-MS	536	647	4.0	4.6	160	100	77.7	79.7	477	61.0
			5.5	6.3	220	200	78.0	80.0	535	72.0
			7.5	8.6	325	300	78.3	80.3	535	77.5
K09-MS	663	800	5.5	6.3	175	100	78.2	80.2	547	77.0
			7.5	8.6	250	200	78.5	80.5	547	84.0
			11.0	12.5	375	325	79.0	81.0	672	114.0
K10-MS	782	944	7.5	8.6	175	125	78.5	80.5	547	86.0
			11.0	12.5	275	250	79.4	81.4	672	116.0
			15.0	17.0	400	400	79.6	81.6	672	130.0
K11-MS	915	1105	7.5	-	125	-	80.0	-	552	93.0
			11.0	12.5	225	175	80.4	82.4	677	123.0
			15.0	17.0	375	325	80.7	82.7	677	137.0
			18.5	21.5	400	400	83.6	85.6	699	155.0

(1) Noise measured at 1 m distance with inlet and outlet ports piped, in accordance to ISO 3744.

- For proper use, the blower should be equipped with inlet filter and safety valve; other accessories available on request.
- Admissible room temperature and suction temperature from -15°C to +40°C.
- Specifications subject to change without notice.



# LATERAL CHANNEL BLOWERS - COMPRESSORS

## SCL K07 / K75 / K08 / K09 / K10 / K11

### MS SERIES - MOR ATEX RANGE

SN2272-2 2/2

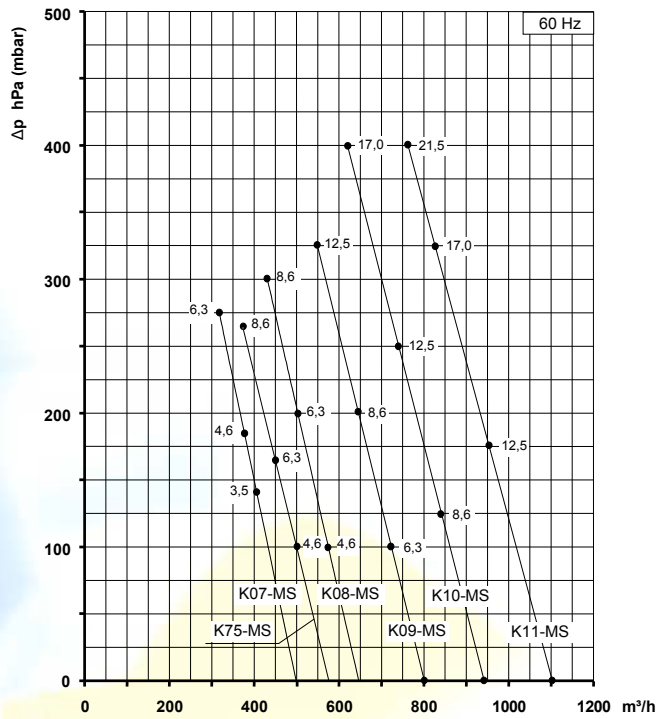
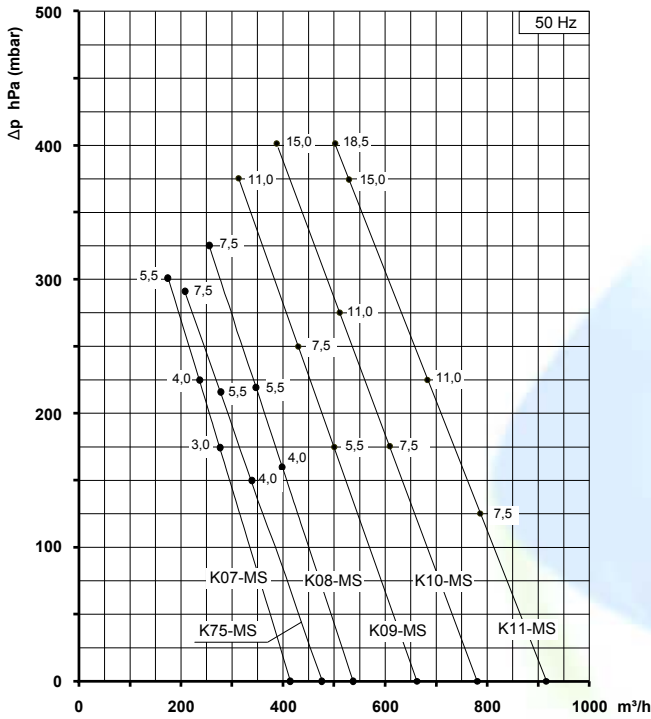

CAPACITY

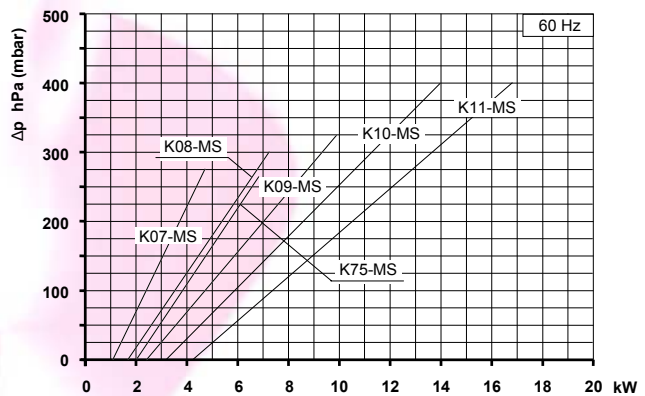
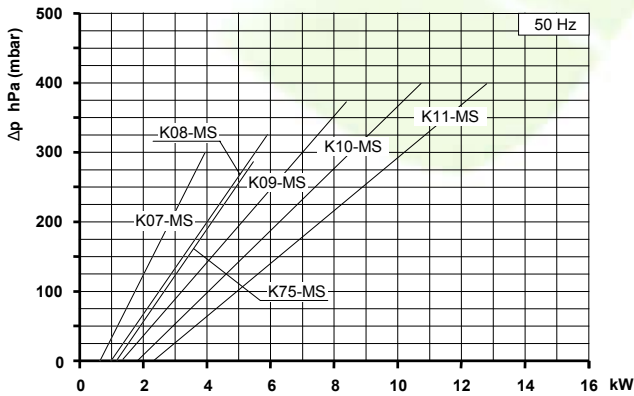

ABSORBED POWER

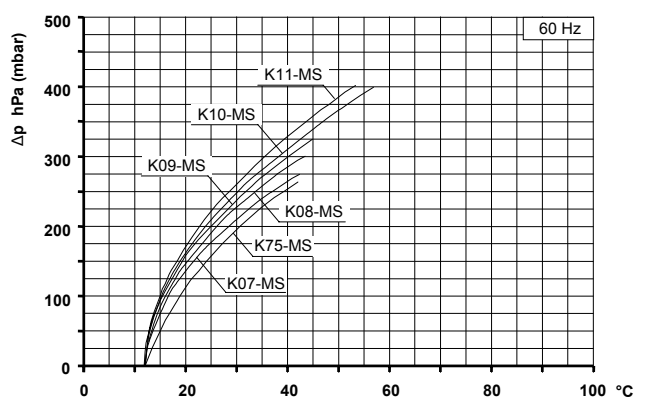
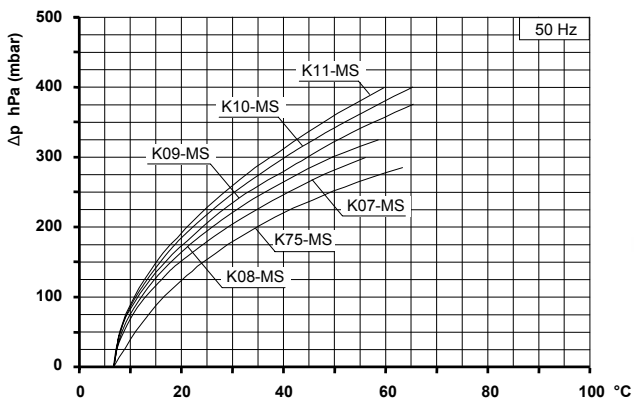

TEMPERATURE INCREASE

Curves refer to air at 20°C temperature and 1013 mbar (abs) atmospheric pressure measured at inlet port.  
 Values for flow, power consumption and temperature rise: +/-10% tolerance.  
 Data can change without prior notice.